

AIR-BLOCK[®] GTo60

The Cable Grommet that seals in a "CLICK"



The GTo60 Air-Block[®] cable grommet is a smart split gasket seal grommet. The 42mm deep grommet fits a 150mm diameter opening in the access floor panel. The GTo60 Air-Block's revolutionary 2 piece design* removes the need for an outer housing ring, and allows quick and easy installation of the grommet. Once cabled, insert grommet into the formed opening and engage the 2 quick lock clamping screws. No additional drilling is required and the unit can be removed as easily as it was installed. The standard flame retardant gasket has 4 optional gasket knockouts. Gaskets can also be made to order and a brush seal version GTo60-BR is also available. The retained centre cover forms a solid lid unit when the grommet is not cabled. The GTo60 was successfully tested to a point load of 450kg. Independent air seal testing also gave the GTo60 excellent sealing results.

Sealing around under-floor air cooled cable openings offers the following benefits:

- Reduced air-loss and increased static press for under-floor air installations.
- Improved cooling efficiencies and extended cooling equipment life.
- Reduced cooling plant running costs.
- Facilitates Cold/Hot Aisle best practice.
- Seals cable openings to prevent under-floor contamination.

Air-Block GTo60 features:

- Fits a 150mm diameter floor panel cut out (can be located in either one panel or 2 adjoining panels).
- The split grommet design allows for easy cable capture and release.
- The design* offers improved floor panel location options.
- With no outer housing, hole cutting is less onerous.
- Made from high strength flame retardant ABS the unit is anti-static.
- RoHS compliant.
- Load tested to 450kg.
- Available colour options - Black (with grey insert lid) & Grey.
- Quick Spring Clamp Design with body matching screw cover plug inserts.
- Maximum cable mouth area: 95mm x 40mm.
- Brush gasket option. Ref: GTo60-BR.

* Patented - Registered Design

Gromtec Europe has supplied cable grommets and flooring accessories for over 15 years. Our products are installed in projects around the world. All units are typically available from stock for immediate delivery.

Contact Details - Intl. tel.: 00353 1 2302117; UK tel.: 0203 2867949; email: gromeu@indigo.ie

www.air-guard.com

www.gromtec.com

AIR|BLOCK[®]

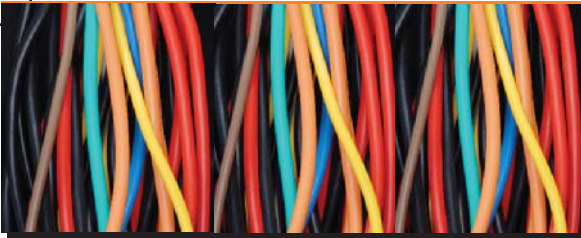

AIR-BLOCK[®] GTo6

The Cable Grommet that seals in a "CLICK"

1

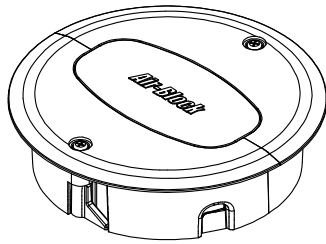

4

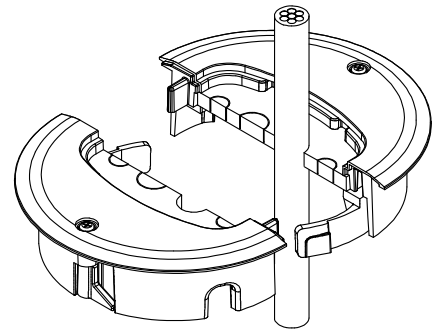

2

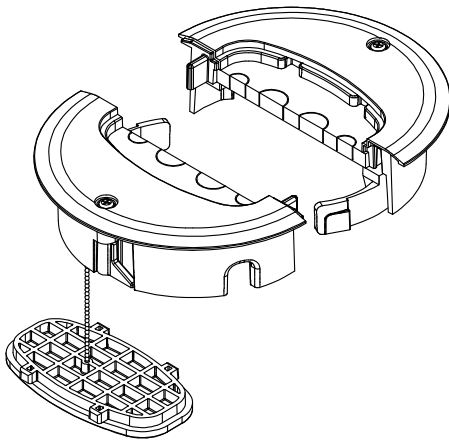

5

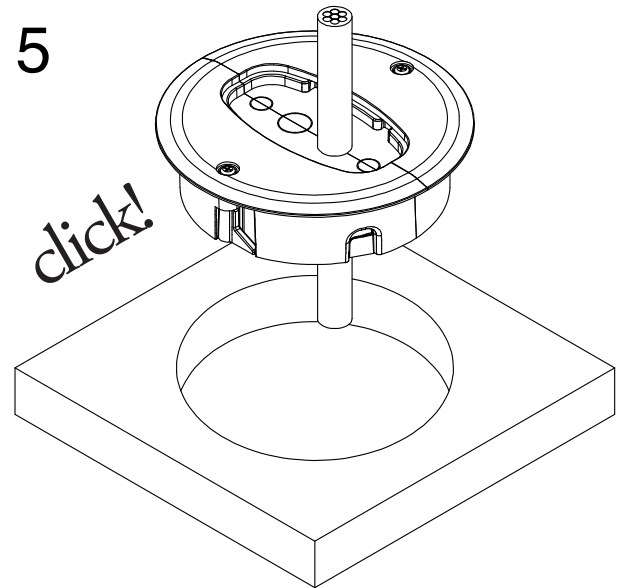

3

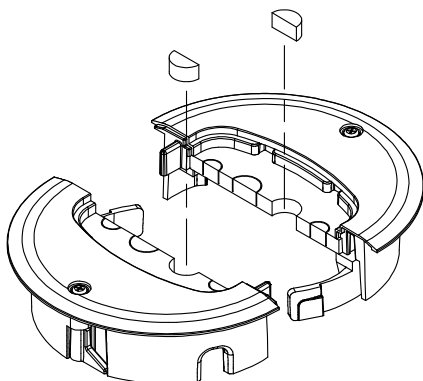

6

