

AIR-BLOCK[®] GT036

The Cable Grommet that seals in a “CLICK”



The GT036 Air-Block[®] cable grommet is a smart rectangular 2 part gasket sealed grommet. The rectangular grommet offers an exciting alternative cabling option to designers and engineers. The GT036 unit is designed to “snap” around cables to provide a safe cushioned air block grommet. The GT036 Air-Block[®] cable mouth measures a generous 150mm x 60mm and is fitted with a die cut flame retardant anti-static gasket. The unit is easy to open, and just as easy to close. The GT036 fits into a 200mm x 110mm floor panel opening. Four built-in quick action fixings lock the grommet into the panel without the need for additional drilling and screw fixing. The grommet's unique design allows the unit to be positioned almost anywhere within, or between floor panels. As the grommet does not require an outer housing, cables are not trapped within the frame of a housing and can be quickly released from the 2 part lid. The GT036 is equally suited to both computer hall and general office installations.

Made from flame retardant materials the GT036 Air-Block grommet is designed as a heavy duty unit. The units' retained centre cover forms a solid safety lid when the grommet is not cabled. Point load tested to 450kg.

Sealing around under-floor air cooled cable openings offers the following benefits:

- Reduced air-loss and increased static press for under-floor air installations.
- Improved cooling efficiencies and extended cooling equipment life.
- Reduced cooling plant running costs.
- Facilitates Cold/Hot aisle best practice.
- Seals cable openings to prevent under-floor contamination.

Air-Block[®] GT036 features:

- The split grommet design allows for easy cable capture and release.
- The design patent* offers improved floor panel location options.
- With no outer housing, hole cutting is less onerous.
- Made from high strength flame retardant ABS plastic, the unit is inherently Anti-static.
- RoHS compliant.
- Additional custom gasket options available.
- Available colour options - Black & Grey.
- Fits a 200mm x 110mm floor panel cut out.
- Overall Dimensions – 225mm x 138mm x 42mm.
- Maximum cable mouth area – 150mm x 60mm.
- The Air-Block[®] grommet has been independently air seal and point load tested.

* Patented - Registered Design

Gromtec Europe has supplied cable grommets and flooring accessories for over 15 years. Our products are installed in projects around the world. All our units are typically available from stock for immediate delivery.

Contact Details - Intl. tel.: 00353 1 2302117; UK tel.: 0203 2867949; email: gromeu@indigo.ie

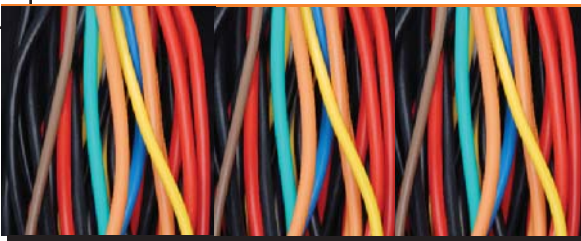

AIR-BLOCK[®] GT03

The Cable Grommet that seals in a "CLICK"

1

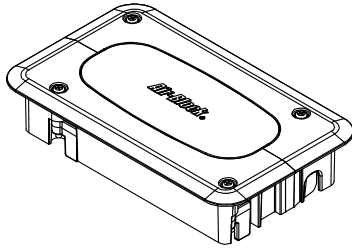

4

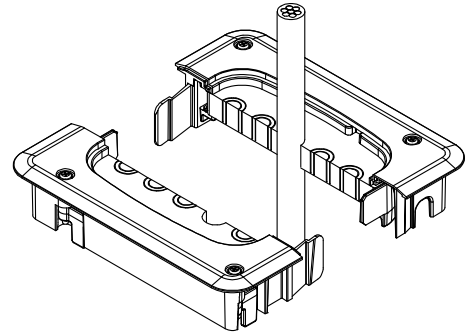

2

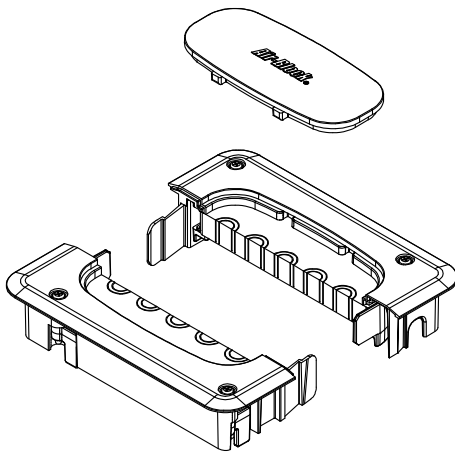

5

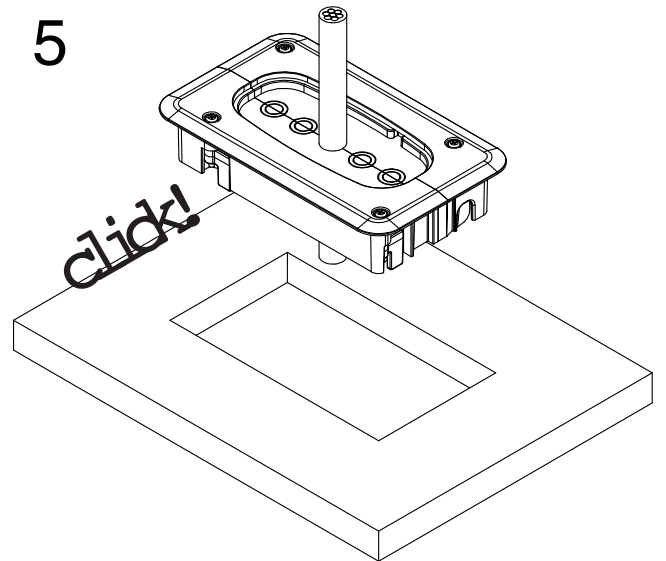

3

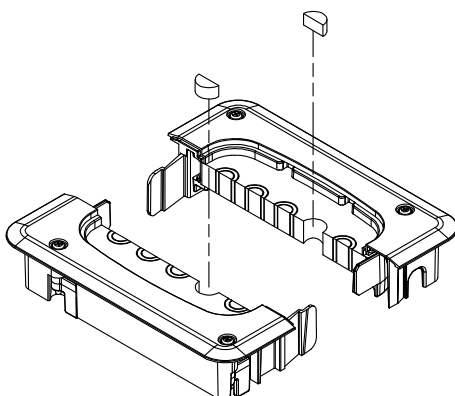

6

